

LG 43" Projected Capacitive Touch Overlay

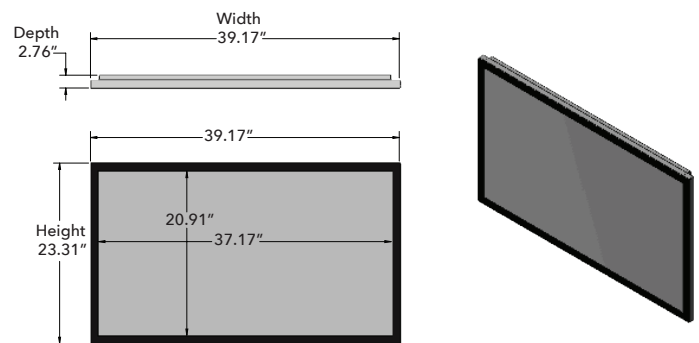

Projected Capacitive Interactive Solution

TSItouch's line of projected capacitive touch displays are engineered specifically for commercial customers who are looking for a rugged and durable touch screen that does not sacrifice on image quality. Featuring a seamless flat front bezel design, the monitor can easily be wiped clean, eliminating any worries about dust and dirt collection. This helps extend the use of the display and enhances the touch experience.



Multi-Touch Screen
 True multi-touch support with up to 40, 80, or 100 simultaneous touch points for all major operating systems



Easy Integration
 Unrivaled simplicity makes installation easier and faster



Ultra-Fast Response Time
 Allows for split second reactions between touch point and screen. Rapid and smooth touch response



HID Compliant
 Maximum compatibility with numerous operating systems, plug-and-play



Superior Design
 Zero bezel flat front, tempered glass touch screen with excellent optical performance



Easy to Clean
 Water and dust resistant

Specifications

Display Compatible	43UX340C
Part Number	TSI43NLMCPGJGZZ
Protective Glass	1/8" Anti-Glare Tempered Glass
Frame Material	Black Powder Coated Cold Rolled Steel
Touch Technology	PCAP
Touch Points	80 Point
Response Time	6 - 16ms
Touch Accuracy	+/- 2mm (Over 99% Area)
Interface	Type A USB/M
Communication	USB 2.0
Power Supply Mode	USB
Width/Height/Depth Including Monitor	39.17" x 23.31" x 2.76"
Weight (Without Monitor)	26.90 lbs
Boxed Weight	31.23 lbs
Boxed Dimensions	41.00" x 25.75" x 5.50"
OS Support	Windows, Google Chrome, Android, Mac, Linux