

Samsung DB55D/E, DM55D/E, DH55D/E Touch Screen Overlay

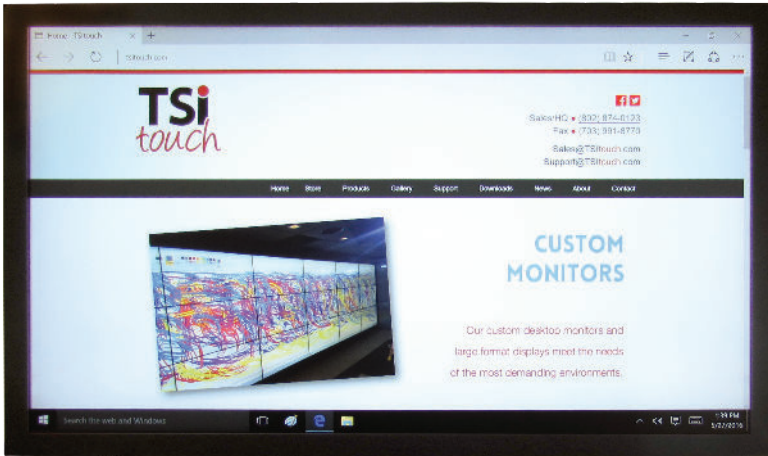

Samsung Authorized Solution

SAMSUNG

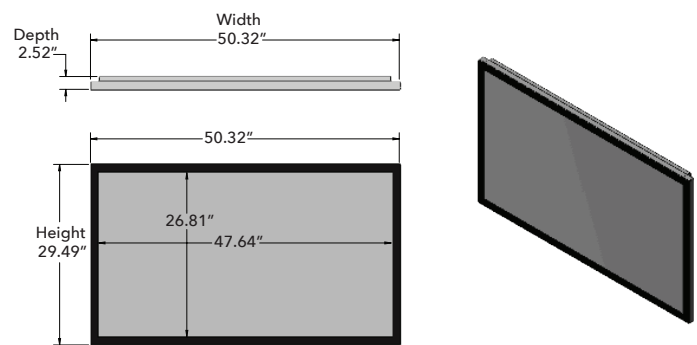

Advanced Interactive Collaboration Solution

TSitouch's line of projected capacitive touch displays are engineered specifically for consumer and commercial customers who are looking for a rugged and durable touch screen without having to sacrifice on image quality. Featuring a seamless flat front bezel design, the monitor can easily be wiped clean, thereby eliminating having to worry about dust and dirt collection, which helps extend the use of your display and enhances your touch experience.



Multi-Touch Screen

True multi-touch support with up to eighty simultaneous touch points for all major operating systems



Easy Integration

Unrivaled simplicity makes installation easier and faster



Ultra-Fast Response Time

Allows for split second reactions between touch point and screen



HID Compliant

Maximum compatibility with numerous operating systems, plug-and-play



Superior Design

Zero bezel flat front, anti-glare touch screen, excellent optical performance



Easy to Clean

Water and dust resistant

Specifications

Display Compatible	DB55D/E, DM55D/E, DH55D/E, DC55E
Part Number	TBD
Protective Glass	1/8" Anti-Glare Tempered Glass
Frame Material	Black Powder Coated Cold Rolled Steel
Touch Technology	PCAP
Touch Points	80 Point
Response Time	6 - 16ms
Touch Accuracy	+/- 2mm (Over 99% Area)
Interface	Type A USB/M
Communication	USB 2.0
Remote Control Receiver	Extender Needed
Receiver Extender	BN39-01899A
Power Supply Mode	USB
Width/Height/Depth Including Monitor	50.32" x 29.49" x 2.52"
Weight (Without Monitor)	39.90 lbs
Boxed Weight	48.87 lbs
Boxed Dimensions	52.25" x 31.25" x 7.50"
OS Support	Windows, Google Chrome, Android, Mac, Linux